

BI-PUMP

**MANUALE
D'USO E
MANUTENZIONE**

ITALIANO

**USE AND
MAINTENANCE
MANUAL**

ENGLISH

Q ESPLOSI

EXPLODED DIAGRAMS

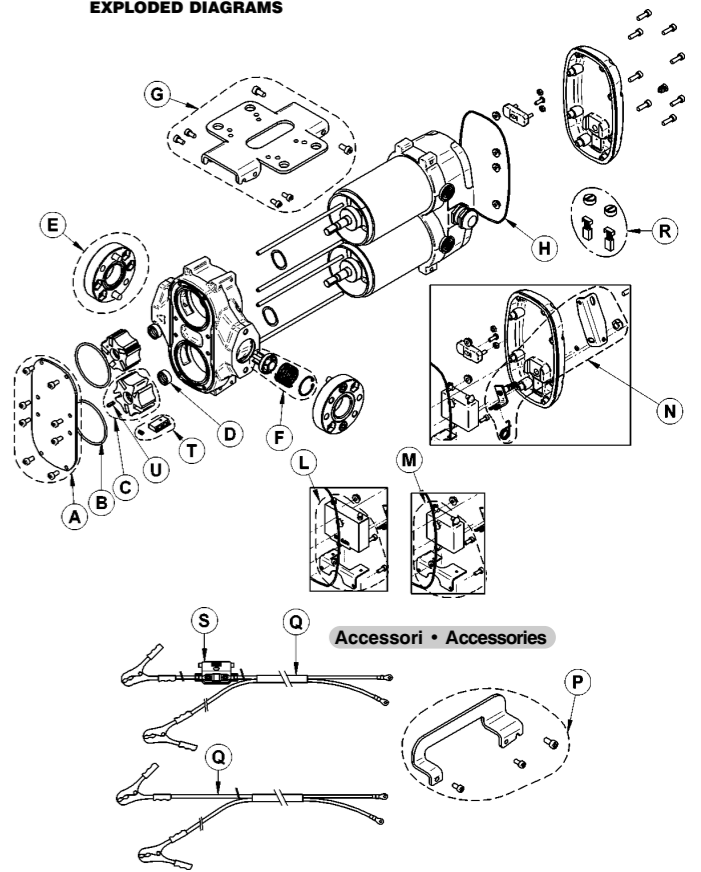

R INGOMBRI • DIMENSIONS

Unità di misura: mm
Unit of measurement: mm

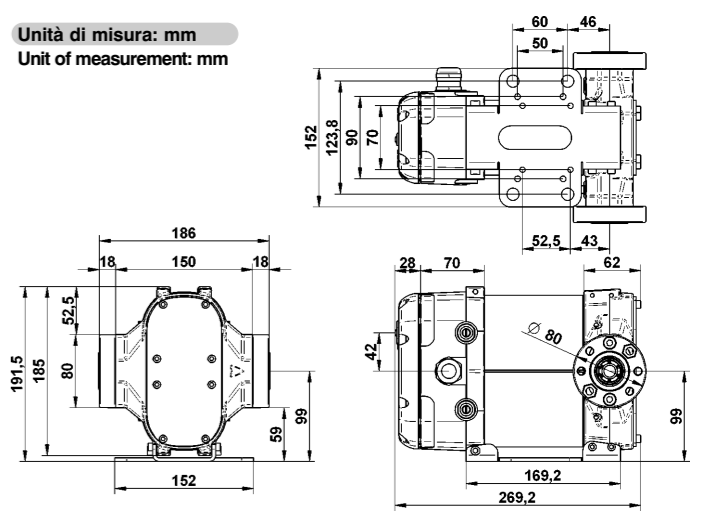

ENGLISH

Respect the following (not exhaustive) instructions to ensure a proper electrical installation.

- During installation and maintenance, make sure that the electric supply lines are not live.
- Use cables characterized by the minimum cross-sections, nominal voltages and wiring-type adequate to the electrical characteristics shown in Paragraph E2 - ELECTRICAL SPECIFICATIONS and the installation environment.
- Always close the cover of the terminal strip box before supplying electrical power.
- Make sure the electrical connections are suitably protected

I INITIAL START-UP / SAFETY

- Check that the quantity of diesel fuel in the suction tank is greater than the amount you wish to transfer.
- Make sure that the residual capacity of the delivery tank is greater than the quantity you wish to transfer.
- Do not run the pump dry. This can cause serious damage to its components.
- Make sure that the tubing and line accessories are in good condition. Diesel fuel leaks can damage objects and injure persons.
- Never start or stop the pump by connecting or cutting out the power supply.
- Do not operate switches with wet hands.
- Prolonged contact with diesel fuel can damage the skin. The use of glasses and gloves is recommended.

ATTENTION

Extreme operating conditions can raise the motor temperature. Turn off the pump and wait for it to cool before resuming use.

In the priming phase the pump must blow the air initially present in the entire installation out of the delivery line. Therefore it is necessary to keep the outlet open to permit the evacuation of the air.

ATTENTION

If an automatic type dispensing nozzle is installed on the end of the delivery line, the evacuation of the air will be difficult because of the automatic stopping device that keeps the valve closed when the line pressure is too low. It is recommended that the automatic dispensing nozzle be temporarily disconnected during the initial start-up phase.

The priming phase can last from several seconds to a few minutes, as a function of the characteristics of the system. If this phase is prolonged, stop the pump and verify:

- That the pump is not running completely dry;
- That the suction tubing is not allowing air to seep in;
- That the suction filter is not clogged;
- That the suction height is not higher than 2 m (if the height is higher than 2 m, fill the suction tube with fluid);
- That the delivery tube is allowing the evacuation of the air.

When priming has occurred, verify that the pump is operating within the anticipated range, in particular:

- That under conditions of maximum back pressure, the power absorption of the motor stays within the values shown on the identification plate;
- That the suction pressure is not greater than 0.5 bar;
- That the back pressure in the delivery line is not greater than the maximum back pressure anticipated for the pump.

L DAILY USE

- If using flexible tubing, attach the ends of the tubing to the tanks. In the absence of an appropriate slot, solidly grasp the delivery tube before beginning dispensing.
 - Before starting the pump make sure that the delivery valve is closed (dispensing nozzle or line valve).
 - Turn the ON/OFF switch to ON.
- The by-pass valve allows functioning with the delivery closed for only brief periods.
- Open the delivery valve, solidly grasping the end of the tubing.
 - Close the delivery valve to stop dispensing.
 - When dispensing is finished, turn off the pump.

ATTENTION

Functioning with the delivery closed is only allowed for brief periods (2 / 3 minutes maximum). The operation in nominal conditions is restricted to a working cycle of 30 minutes. Should this period be exceeded, turn off the pump and wait for it to cool. After use, make sure the pump is turned off.

M PROBLEMS AND SOLUTIONS

PROBLEM	POSSIBLE CAUSE	CORRECTIVE ACTION
THE MOTOR IS NOT TURNING	Lack of electric power	Check the electrical connections
	Rotor jammed	Check for possible damage or obstruction of the rotating components.
	Motor problems	Contact the Service Department
THE MOTOR TURNS SLOWLY WHEN STARTING	Low voltage in the electric power line	Bring the voltage back within the anticipated limits
	Low level in the suction tank	Refill the tank
LOW OR NO FLOW RATE	Foot valve blocked	Clean and/or replace the valve
	Filter clogged	Clean the filter
	Excessive suction pressure	Lower the pump with respect to the level of the tank or increase the cross-section of the tubing
	High loss of head in the delivery circuit (working with the by-pass open)	Use shorter tubing or of greater diameter
	By-pass valve blocked	Dismantle the valve, clean and/or replace it
	Air entering the pump or the suction tubing	Check the seals of the connections
	A narrowing in the suction tubing	Use tubing suitable for working under suction pressure
	Low rotation speed	Check the voltage at the pump. Adjust the voltage and/or use cables of greater cross-section
	The suction tubing is resting on the bottom of the tank	Raise the tubing
	INCREASED PUMP NOISE	Cavitation occurring
Irregular functioning of the by-pass		Dispense fuel until the air is purged from the by-pass system
LEAKAGE FROM THE PUMP BODY	Air present in the diesel fuel	Verify the suction connections
	Seal damaged	Check and replace the seal

N MAINTENANCE

BI-PUMP is designed and constructed to require a minimum of maintenance.

- On a weekly basis, check that the tubing joints have not loosened, to avoid any leakage.
- On a monthly basis, check the pump body and keep it clean of any impurities.
- Check weekly and keep the installed suction line filter.
- On a monthly basis, check that the electric power supply cables are in good condition.
- Check monthly for the presence of grease on the contact surface between terminal box cover and terminal box body.

O NOISE LEVEL

Under normal working conditions the noise emission from all models does not exceed the value of 70 db at a distance of 1 meter from the electric pump.

P DISPOSING OF CONTAMINATED MATERIALS

In the event of maintenance or demolition of the machine, do not disperse contaminated parts into the environment. Refer to local regulations for their proper disposal.

ENGLISH

H5 CONSIDERATIONS REGARDING DELIVERY AND SUCTION LINES

DELIVERY

The choice of pump model must be made keeping the characteristics of the system in mind.

The combination of the length of the tubing, the diameter of the tubing, the flow rate of the diesel fuel and the line accessories installed can create back pressure greater than the maximums anticipated such as to cause the

(partial) opening of the pump by-pass with the consequent noticeable reduction of the flow rate supplied.

In such cases, to allow correct functioning of the pump, it is necessary to reduce system resistance, using shorter tubing and/or of wider diameter and line accessories with less resistance (e.g., an automatic dispensing nozzle for greater flow rates).

SUCTION

BI-PUMP is a self-priming pump characterized by excellent suction capacity.

During the start-up phase, with an empty suction tube and the pump wetted with fluid, the electric pump unit is capable of suctioning the liquid with a maximum difference in height of 2 meters. It is important to point out that the priming time can be as long as one minute and the presence of an automatic dispensing nozzle on the delivery line prevents the evacuation of air from the installation, and, therefore, prevents proper priming.

For this reason, it is always advisable to prime the pump without an automatic delivery nozzle, verifying the proper wetting of the pump.

The installation of a foot valve is recommended to prevent the emptying of the suction tube and keep the pump wet. In this way, the pump will subsequently always start up immediately.

When the system is functioning, the pump

can work with pressure at the inlet as high as 0.5 bar, beyond which cavitation phenomena can begin, with a consequent loss of flow rate and increase of system noise.

As we have said up to this point, it is important to guarantee low suction pressure by using short tubing of a diameter equal to or larger than recommended, reducing curves to a minimum and using suction filters of wide cross-section and foot valves with the lowest possible resistance. It is very important to keep the suction filters clean because, once clogged, they increase system resistance.

The difference in height between the pump and the fluid level must be kept as small as possible and, at any rate, within the 2 meters anticipated for the priming phase.

If this height is exceeded, it will always be necessary to install a foot valve to allow for the filling of the suction tube and provide tubing of wider diameter. It is recommended that the pump not be installed at a difference in height greater than 3 meters.

ATTENTION

In the case that the suction tank is higher than the pump, it is advisable to install an anti-siphon valve to prevent accidental diesel fuel leaks.

Dimension the installation in order to control the back pressures due to water hammering.

H6 ACCESSORIES

Following is a list of the most common accessories whose use is compatible with the proper functioning of the pumps.

DELIVERY	SUCTION	ELECTRICAL POWER SUPPLY
Automatic dispensing nozzle	Foot valve with filter	Line cord, 2 m
Manual dispensing nozzle	Rigid and flexible tubing	Line cord, 4 m
Meter	Suction filter	
Flexible tubing		

ATTENTION

It is the installer's responsibility to provide the accessories necessary for the safe and proper functioning of the pump.

The use of accessories unsuitable for use with diesel fuel can damage the pump, injure persons and cause pollution.

H7 ELECTRICAL CONNECTIONS

The pump is supplied without power cord

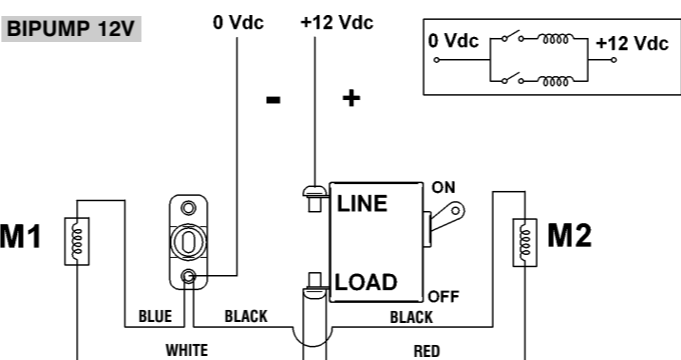

In the event of a 12V connection without switch, connect the white and red cables directly to the positive pole (+).

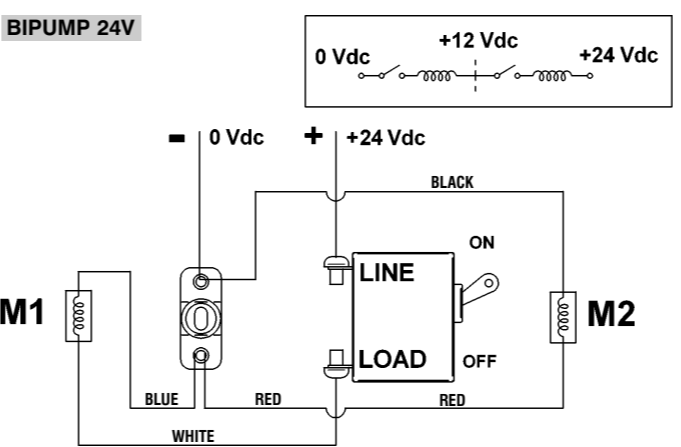

In the event of a 24V connection without switch, connect the white cable directly to the positive pole (+).

ATTENTION

IT IS THE INSTALLER'S RESPONSIBILITY TO PERFORM THE ELECTRICAL CONNECTIONS WITH RESPECT FOR THE APPLICABLE REGULATIONS.

Before closing the terminal strip box, apply a layer of grease to the seat of the Or-gasket

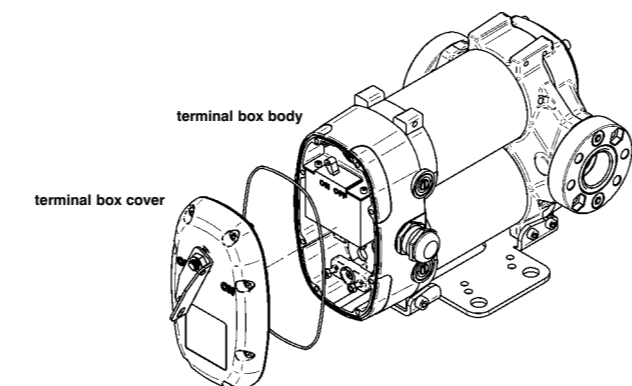

ENGLISH

E2 ELECTRICAL SPECIFICATIONS

PUMP MODEL	RPM	ELECTRICAL POWER		
		Current	Voltage (V)	Maximum (*) (Amp)
BIPUMP 12 V	2200	DC	12	44
BIPUMP 24 V	2200	DC	24	22.5

(*)Refers to functioning with maximum back pressure.

F OPERATING CONDITIONS

F1 ENVIRONMENTAL CONDITIONS

TEMPERATURE: min. -20°C / max +60°C
RELATIVE HUMIDITY: max. 90%

ATTENTION

The temperature limits shown apply to the pump components and must be respected to avoid possible damage or malfunction.

F2 ELECTRICAL POWER SUPPLY

Depending on the model, the pump must be supplied by a single-phase alternating current line whose nominal values are shown in the table in Paragraph E2 - ELECTRICAL SPECIFICATIONS. The maximum acceptable variations from the electrical parameters are:
Voltage: +/- 5% of the nominal value

ATTENTION

Power from lines with values outside of the indicated limits can damage the electrical components.

F3 WORKING CYCLE

Pumps are designed for intermittent use with an operating cycle of 30 minutes under conditions of maximum back-pressure.

ATTENTION

Functioning under by-pass conditions is only allowed for brief periods of time (2-3 minutes maximum).

F4 FLUIDS PERMITTED / FLUIDS NOT PERMITTED

PERMITTED:
• DIESEL FUEL at a VISCOSITY of from 2 to 5.35 cSt (at a temperature of 37.8°C) Minimum Flash Point (PM): 55°C

NOT PERMITTED:

- GASOLINE
- INFLAMMABLE LIQUIDS WITH PM < 55°C
- LIQUIDS WITH VISCOSITY > 20 cSt
- WATER
- FOOD LIQUIDS
- CORROSIVE CHEMICAL PRODUCTS

- SOLVENTS

- AD-BLUE

RELATED DANGERS:

- FIRE - EXPLOSION
- INFLAMMABLE LIQUIDS WITH PM < 55°C
- MOTOR OVERLOAD
- PUMP OXIDATION
- CONTAMINATION OF THE SAME
- PUMP CORROSION
- INJURY TO PERSONS
- FIRE - EXPLOSION
- DAMAGE TO GASKET SEALS
- PUMP OXIDATION

G MOVING AND TRANSPORT

Given the limited weight and size of the pumps (see overall dimensions), moving the pumps does not require the use of lifting devices. The pumps were carefully packed before shipment. Check the packing material on delivery and store in a dry place.

H INSTALLATION

H1 DISPOSING OF THE PACKING MATERIAL

The packing material does not require special precautions for its disposal, not being in any way dangerous or polluting. Refer to local regulations for its disposal.

H2 PRELIMINARY INSPECTION

- Check that the machine has not suffered any damage during transport or storage.
- Clean the inlet and outlet openings, removing any dust or residual packing material.
- If the pump is supplied with line cords, check that the electrical specifications correspond to those shown on the identification plate.

H3 POSITIONING THE PUMP

- The pump can be installed in any position (pump axis vertical or horizontal)
- Attach the pump using screws of adequate diameter for the attachment holes provided in the base of the pump (see the section "OVERALL DIMENSIONS" for their position and dimension).

ATTENTION

THE MOTORS ARE NOT OF AN ANTI-EXPLOSIVE TYPE. Do not install them where inflammable vapors can be present.

H4 CONNECTING THE TUBING

- Before connection, make sure that the tubing and the suction tank are free of dirt and thread residue that could damage the pump and its accessories.
- Before connecting the delivery tube, partially fill the pump body with diesel fuel to facilitate priming.
- Do not use conical threaded joints that could damage the threaded pump openings if excessively tightened.
- The pump is not equipped with filter. Always install a suction filter.

SUCTION TUBING

- Minimum recommended nominal diameter: 1 1/4"
- Nominal recommended pressure: 10 bar.
- Use tubing suitable for functioning under suction pressure

DELIVERY TUBING

- Minimum recommended nominal diameter: 1"
- Nominal recommended pressure: 10 bar

ATTENTION

It is the installer's responsibility to use tubing with adequate characteristics.

The use of tubing unsuitable for use with diesel fuel can damage the pump, injure persons and cause pollution. Loosening of the connections (threaded connections, flanging, gasket seals) can cause serious ecological and safety problems. Check all the connections after the initial installation and on a daily basis after that. Tighten the connections, if necessary.

ENGLISH

A INDEX

- A Index
- B Machine and Manufacturer Identification
- C Declaration of Incorporation
- B Machine Description
- E Technical Specifications
 - E1 Performance Specifications
 - E2 Electrical Specifications
 - F Operating Conditions
 - F1 Environmental Conditions
 - F2 Electrical Power Supply
 - F3 Working Cycle
 - F4 Fluids Permitted / Fluids Not Permitted
 - G Moving and Transport
 - H Installation
 - H1 Disposing of the Packing Material
 - H2 Preliminary Inspection
 - H3 Positioning the Pump
 - H4 Connecting the Tubing and Suction Lines
 - H5 Considerations Regarding Delivery and Suction Lines
 - H6 Line Accessories
 - H7 Electrical Connections
 - I Initial Start-Up
 - L Daily Use
 - M Problems and Solutions
 - N Maintenance
 - O Noise Level
 - P Disposing of Contaminated Materials
 - Q Exploded diagrams and spare parts
 - R Dimensions

B MACHINE AND MANUFACTURER IDENTIFICATION

Available Models: • BIPUMP 12 V
• BIPUMP 24 V
MANUFACTURER: PIUSI SPA
VIA PACINOTTI - Z.I. RANGAVINO
46029 SUZZARA (MN)

IDENTIFICATION PLATE (EXAMPLE WITH THE FIELDS IDENTIFIED):



ATTENTION

Always check that the revision level of this manual coincides with what is shown on the identification plate.

C DECLARATION OF INCORPORATION

DECLARATION OF INCORPORATION

The undersigned PIUSI S.p.A.
Via Pacinotti, Z.I. Rangavino
46029 Suzzara (Mantova) – Italy

Declares under its own responsibility that the machine:
BIPUMP 12 / 24 V

described below:

Machine designed for the transfer of diesel fuel

is manufactured to be incorporated into a machine or to be assembled with other machinery to build a machine according to the Machine Directive 98/37/CE.

Moreover, we declare that the machinery cannot be put into operation until the machine in which it will be incorporated and of which it will become a component, has been identified and its compliance with the Machine Directive 98/37/CE has been declared.

Suzzara 01.09.2005

Otto Varini
OTTO VARINI, Chairman

D MACHINE DESCRIPTION

PUMP: Self-Priming, volumetric, rotating vane pump, equipped with by-pass valve.

MOTOR: Brush motor powered by intermittent direct current, low voltage, closed type, protection class IP55 according to CEI-EN 60034-5, flange-mounted directly to the pump body.

E TECHNICAL SPECIFICATIONS

E1 PERFORMANCE SPECIFICATIONS

The performance diagram shows flow rate as a function of back pressure.

Functioning Point	Model	Flow Rate (l/min)	Back Pressure P2 bar	Absorption
A (max. flow rate)	Bipompa 12V	76 - 82	0,4	24 - 27
	Bipompa 24V	76 - 82	0,4	12 - 14
B (normal flow rate)	Bipompa 12V	72 - 76	0,9	29 - 32
	Bipompa 24V	72 - 76	0,9	15 - 17
C (Bypass)	Bipompa 12V	-	1,7	35 - 43
	Bipompa 24V	-	1,7	18 - 22

* Delivery plant consisting of K33/K44 meter, 5 mt. 1" tube and A80 nozzle

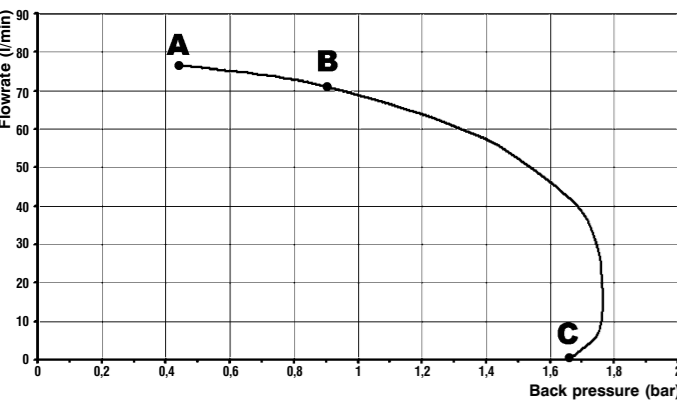

ATTENTION

The curve refers to the following operating conditions:

Fluid Diesel Fuel
Temperature 20°C
Suction Conditions The tube and the pump position relative to the fluid level is such that a pressure of 0.3 bar is generated at the nominal flow rate.

Under different suction conditions higher pressure values can be created that reduce the flow rate compared to the same back pressure values.

To obtain the best performance, it is very important to reduce loss of suction pressure as much as possible by following these instructions:

- Shorten the suction tube as much as possible
 - Avoid useless elbows or throttling in the tubes
 - Keep the suction filter clean
 - Use a tube with a diameter equal to, or greater than, indicated (see Installation)
- The burst pressure of the pump is of 20bar.