

ENGLISH
(Translated from Italian)

A INDEX

- A Index
- B Machine and manufacturer identification
- C Declaration of incorporation of partly-completed machinery
- D Machine description
- E General notes
 - E1 Moving and transport
 - E2 General informations
 - E3 First aid rules
 - E4 Using and looking after manuals
 - E5 Disposing of contaminated materials
- F Technical data
 - F1 Performance specifications
 - G Electrical specifications
 - H Operating conditions
 - H1 Environmental conditions
 - H2 Electrical power supply
 - H3 Working cycle
 - H4 Fluids permitted / fluids not permitted
- I Installation
 - I1 Preliminary inspection
 - I2 Positioning the pump
 - I3 Notes on suction and delivery lines
 - I3.1 Delivery
 - I3.2 Suction
 - I4 Configuration and accessories
 - I5 Line accessories
- L Connections
 - L1 Electrical connections
 - L2 Connecting the piping
- M Initial start-up
- N Daily use
- O Maintenance
- P Noise level
- Q Problems and solutions
- R Exploded views
- S Overall dimensions

B MACHINE AND MANUFACTURER IDENTIFICATION

Available Models: By-pass 3000 12 - 24 Vdc
Carry 3000
Battery kit 3000

PRODUCT CODE: **PIUSI** F00335000 YEAR 2007

MODEL: BY PASS 3000

TECHNICAL DATA: 3200 rpm, 200 W, 25 min, 22 A

DANGER

MANUFACTURER: PIUSI S.p.A. Via Pacinotti Z.I. Rangavino 46029 Suzzara (Mantova) Italy

C DECLARATION OF INCORPORATION OF PARTLY-COMPLETED MACHINERY

The undersigned PIUSI S.p.A. Via Pacinotti c.m.- z.l.Rangavino 46029 Suzzara - Mantova - Italy

HEREBY STATES under its own responsibility, that the partly-completed machinery: Machine for diesel oil transfer Model : By-pass 3000 12 - 24 Vdc / Carry 3000 / Battery kit 3000 Serial number: refer to Lot Number shown on CE plate affixed to product Year of manufacture: refer to the year of production shown on the CE plate affixed to the product. Is intended to be incorporated in a machine (or to be with other machines) so as to create a machine to which applies Machine Directive 2006/42/EC, may not be brought into service before the machine into which it is to be incorporated has been declared in conformity with the provisions of the directive 2006/42/EC. Is in conformity with the legal provisions indicated in the directives : Machine Directive 2006/42/EC - Electromagnetic Compatibility Directive 2004/108/EC

To which the essential safety requirements have been applied and compiled with what indicated on annex I of the machine directive applicable to the product and shown below.

The documentation is at the disposal of the competent authority following motivated request at Piusi S.p.A. or following request sent to the email address: doc_tec@piusi.com

The person authorised to compile the technical file and draw up the declaration is Otto Varini as legal representative.

D MACHINE DESCRIPTION

PUMP: Self-Priming, volumetric, rotating vane pump, equipped with by-pass valve. MOTOR: Brush motor, DC, low tension with intermittent cycle, closed type in protection class IP55 according to CEI-EN 60034-5, directly flanged to the pump body.

E GENERAL NOTES

Before connecting and operating the unit, you must wear your personal protective equipment (PPE).

Make sure that the tubing and line accessories are in good condition. Gasoline leaks can damage objects and injure persons.

During operation a few parts may reach high temperatures and result in burns if touched.

Extreme operating conditions can cause the temperature of the motor to rise and even to stop following the intervention of the electronic controls. Switch off the pump and wait for it to cool down before using again.

ATTENTION Before starting up the system, make sure that pump has been assembled correctly with all lids correctly closed.

E2 FIRST AID RULES

EYES: If the gasoline comes into contact with the eyes, rinse immediately with a lot of water. Emergency measures are not necessary. However, should the eyes show suspicious symptoms, seek medical assistance.

SKIN: Rinse the contaminated part immediately with water and soap. Emergency measures are not necessary, but if the skin shows suspicious symptoms, seek medical assistance.

INHALATION: Take the affected person out into the open air. If s/he does not recover rapidly, seek medical assistance.

ENGLISH
(Translated from Italian)

SWALLOWING: DO NOT INDUCE VOMITING. Emergency measures are not necessary, but should there be signs of illness, seek medical assistance.

ATTENTION PERSONS WHO HAVE SUFFERED ELECTRIC SHOCK: disconnect the power source, or use a dry insulator to protect yourself while you move the injured person away from any electrical conductor. Avoid touching the injured person with your bare hands until he is far away from any conductor. Immediately call for help from qualified and trained personnel. Do not operate switches with wet hands.

E3 USING AND LOOKING AFTER MANUALS

This manual illustrates the main features of pump, providing information regarding: Electrical and mechanical installation. First start-up operations. Daily use. General safety rules. This manual represents an integral and essential part of the product and, according to the provisions of directive 2006/42/EC, must be given to operators and maintenance staff in order to comply with the obligations relating to training/information referred to in directive 2006/42/EC. Carefully read the instructions contained in this manual, as they contain important information regarding installation safety, operation and maintenance. The manufacturer disclaims all liability for injury to persons or damage to things, or to machinery, in the event of this being used in a way different to that indicated in the instructions.

E4 DISPOSING OF CONTAMINATED MATERIALS

In case of maintenance or demolition by the product, the parts that make it up must be sent to companies that specialise in the disposal and recycling of industrial refuse and, in particular, DISPOSAL OF PACKING MATERIAL: The packaging consists of biodegradable cardboard which can be delivered to companies for normal recycling of cellulose. DISPOSAL OF METAL COMPONENTS: Metal parts, whether paint-finished or in stainless steel, aluminium, brass can be consigned to scrap metal collectors. DISPOSAL OF ELECTRIC AND ELECTRONIC COMPONENTS: these have to be disposed by companies that are specialised in the disposal of electronic components, in accordance with the instructions of 2002/96/EC (see text of Directive below).

INFORMATION REGARDING THE ENVIRONMENT FOR CLIENTS RESIDING WITHIN THE EUROPEAN UNION: European Directive 2002/96/EC requires that all equipment marked with this symbol on the product and/or packaging not be disposed of together with non-differentiated urban waste. The symbol indicates that this product should be disposed of separately from regular household waste streams. It is the responsibility of the owner to dispose of these products as well as other electric or electronic equipment by means of the specific refuse collection structures indicated by the government or the local governing authorities.

DISPOSAL OF OTHER PARTS: Other components, such as pipes, rubber gaskets, plastic parts and wires, must be disposed of by companies specialising in the disposal of industrial waste.

F TECHNICAL DATA

F1 PERFORMANCE SPECIFICATIONS

The performance diagram shows flow rate as a function of back pressure.

Functioning Point	Flow Rate	Voltage (V)		Absorption (A)	Typical Delivery Configuration			
		12	15		4 meters of 3/4" tube	K33 Meter	Manual dispensing nozzle	Automatic dispensing nozzle
A (Maximum Flow Rate)	50	12	15	24	8	•	•	•
B (High Flow Rate)	48	12	16	24	8,5	•	•	•
C (Rated Conditions)	46	12	17	24	9	•	•	•
D (By pass)	0	12	21	24	12	Delivery Closed		

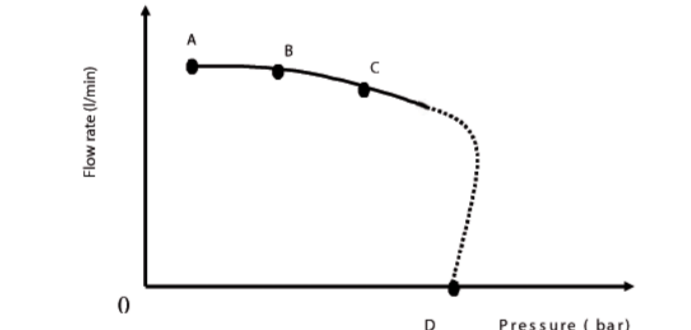

ATTENTION The curve refers to the following operating conditions: Fuel: Diesel Fuel Temperature: 20° C Suction Conditions: The tube and the pump position relative to the fluid level is such that a pressure of 0.3 bar is generated at the nominal flow rate.

Under different suction conditions higher pressure values can be created that reduce the flow rate compared to the same back pressure values. To obtain the best performance, it is very important to reduce loss of suction pressure as much as possible by following these instructions:

- Shorten the suction tube as much as possible
- Avoid useless elbows or controlling in the tubes
- Keep the suction filter clean
- Use a tube with a diameter equal to, or greater than, indicated (see Installation)

G ELECTRICAL SPECIFICATIONS

PUMP MODEL	FUSES	ELECTRICAL POWER		CURRENT
		Current	Voltage (V)	
VERSION 12V	25	DC	12	22
VERSION 24V	15	DC	24	12

(*) referred to operations in by-pass mode

H OPERATING CONDITIONS

H1 ENVIRONMENTAL CONDITIONS

TEMPERATURE: min. -20° C / max +60° C

RELATIVE HUMIDITY: max. 90%

ATTENTION The temperature limits shown apply to the pump components and must be respected to avoid possible damage or malfunction.

ENGLISH
(Translated from Italian)

H2 ELECTRICAL POWER SUPPLY

N.B.: THE PUMP SHOULD BE POWERED BY A SAFE SOURCE: BATTERY OR POWER SUPPLY 12/24V WITH SAFETY TRANSFORMER. In accordance with the model, the pump must be powered by a direct current line, the nominal values of which are indicated on the table in the paragraph "G ELECTRICAL SPECIFICATIONS". The maximum acceptable variations from the electrical parameters are: Voltage: +/- 10% of the nominal value

ATTENTION Power supply from lines with values that do not fall within the indicated limits could cause damage to the electrical components and reduction of working performance.

H3 WORKING CYCLE

The pumps are designed for intermittent use with a working cycle of 30 minutes under maximum back pressure conditions.

ATTENTION Functioning under by-pass conditions is only allowed for brief periods of time (2-3 minutes maximum).

H4 FLUIDS PERMITTED / FLUIDS NOT PERMITTED

- PERMITTED: DIESEL FUEL at a VISCOSITY from 2 to 5.35 cSt (at a temperature of 37.8° C) Minimum Flash Point (FM): 55° C NOT PERMITTED: RELATED DANGERS: - GASOLINE - FIRE - EXPLOSION - INFLAMMABLE LIQUIDS with PM < 55° C - WATER - PUMP OXIDATION - FOOD LIQUIDS - CONTAMINATION OF THE SAME - PUMP CORROSION - INJURY TO PERSONS - SOLVENTS - FIRE - EXPLOSION - DAMAGE TO GASKET SEALS - LIQUIDS WITH VISCOSITY > 20cSt - MOTOR OVERLOAD

I INSTALLATION

I1 PRELIMINARY INSPECTION

- Verify that all components are present. Request any missing parts from the manufacturer.
- Check that the machine has not suffered any damage during transport or storage.
- Carefully clean the suction and delivery inlets and outlets, removing any dust or other packaging material that may be present.
- Make sure that the motor shaft turns freely.
- Check that the electrical data corresponds to those indicated on the data plate - Always install in an illuminated area
- Install the pump in ventilated place to avoid any vapours accumulation.
- We recommend that a suction filter be used.

I2 POSITIONING THE PUMP

The pumps can be installed in any position (with pump axis in vertical or horizontal position). The pump must be securely attached by means of the provided fixing bracket and screws.

ATTENTION THE MOTORS ARE NOT OF THE ANTI-EXPLOSIVE-TYPE. DO NOT install them where inflammable vapours could be present.

I3 NOTES ON SUCTION AND DELIVERY LINES

I3.1 DELIVERY

The selection of the pump model must be made taking into account the characteristics of the system. The combination of the length of the pipe, the diameter of the pipe, the flow rate of the diesel or other liquid, as well as the accessories installed on the line, could create back pressure that are greater than the maximum predicted pressure, thereby causing the pump's electronic controls to intervene and reducing the dispensing flow rate considerably. In these cases, to guarantee correct operation of the pump, it is necessary to reduce the resistance of the system using pipes that are shorter or that have a greater diameter, as well as line accessories with smaller resistances (e.g. an automatic dispensing nozzle with greater flow rate capacity).

I3.2 SUCTION

The self-priming pumps have a good suction capability. During the start-up phase, when the suction pipe is empty and the pump is wet with the fluid, the electric pump unit is able to suck liquid from a maximum vertical distance of 2m. It is important to note that it could take up to 1 minute for the pump to prime and that the presence of an automatic dispensing nozzle on the delivery side will prevent the air trapped during the installation from being released and, therefore, the correct priming of the pump.

For this reason, it is always advisable to prime the pump without an automatic delivery nozzle, verifying the proper wetting of the pump. Always install a foot valve to prevent the suction pipe from being emptied and to keep the pump wet at all times. In this way, the pump will always start up immediately the next times it is used.

When the system is in operation, the pump can operate with back pressures of up to 0.5 bars on the suction inlet; beyond this point, the pump may begin to cavitate resulting in a drop of the flow rate and an increase in the noise levels of the system. In light of this, it is important to guarantee small back pressures on the suction side, by using short pipes with diameters that are equal to or larger than those recommended, reducing bends to a minimum, and using filters with a large cross-section and foot valves with minimum possible resistance on the suction side. It is very important to keep the suction filters clean because, when they become clogged, they increase the resistance of the system. The vertical distance between the pump and the fluid must be kept as short as possible, and it must fall within the 2m maximum required for priming. If the distance is greater, a foot valve must be installed to allow the suction pipes to fill up and the diameter pipes must be larger. It is however recommended that pump not be installed if the vertical distance is greater than 2m.

ATTENTION If the suction tank is higher than the pump, an anti-siphon valve should be installed to prevent accidental diesel fuel leaks. Size the installation to contain the back pressures caused by water hammering.

ATTENTION It is a good system practice to install vacuum and air pressure gauges right at the inlets and outlets of the pump, which allow verification that operating conditions are within anticipated limits. To prevent the suction pipes from being emptied when the pump stops, a foot valve should be installed.

THE INSTALLER IS RECOMMENDED TO INSTALL A SUCTION FILTER.

ENGLISH
(Translated from Italian)

I4 CONFIGURATION AND ACCESSORIES

The wide range of accessories and the possibility to fit the base in different positions allow the pump to be used for different installations. The installation is stationary if the provided fixing bracket is used while it is mobile if the handle is used (if required).

LIST OF ACCESSORIES:

- Fixing bracket
- Straight hosealts
- 90° Curved hosealts
- Coupling 90° with flange 1"
- Handle
- Kit terminal box (with or w/out switch). If the terminal board kit is present and the switch is in position "0", the pump is switched OFF while if the switch in position "1", the pump is working.

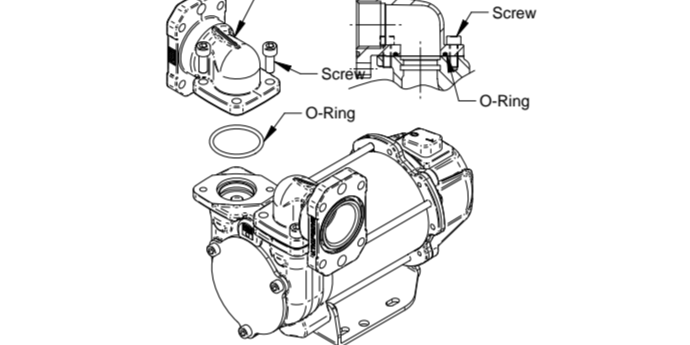
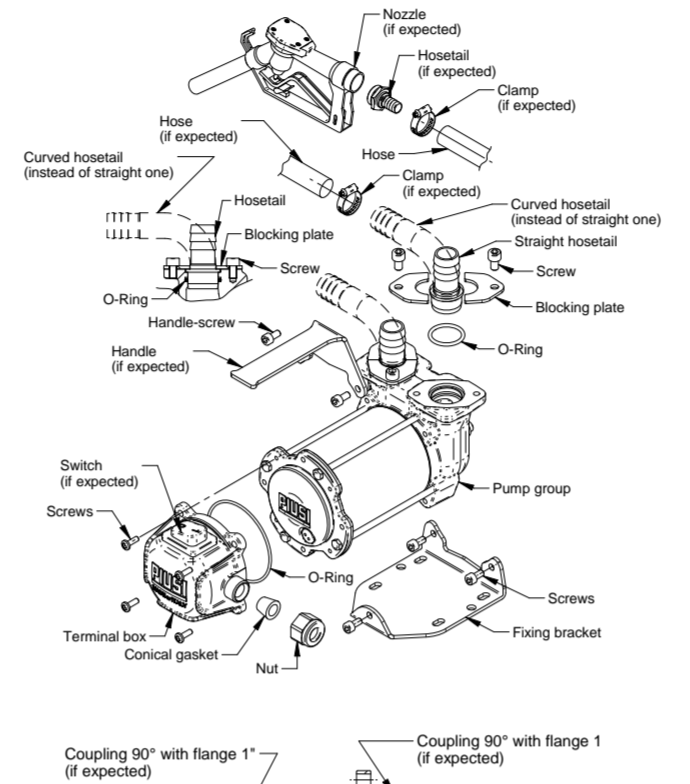

I5 LINE ACCESSORIES

ATTENTION It is the responsibility of the installer to provide the necessary line accessories to ensure the correct and safe operation of the pump. The accessories that are not suitable to be used with the indicated material could damage the pump or cause injury to persons, as well as causing pollution.

IT IS THE INSTALLER'S RESPONSIBILITY TO APPLY THE FOLLOWING SIGNALS ON THE MACHINE ANYWHERE PUMP WILL BE USED.

L CONNECTIONS

L1 ELECTRICAL CONNECTIONS

GENERAL WARNINGS: IT IS THE RESPONSIBILITY OF THE INSTALLER TO CARRY OUT THE ELECTRICAL CONNECTIONS IN COMPLIANCE WITH THE APPLICABLE REGULATIONS.

- Comply with the following (not exhaustive) instructions to ensure a proper electrical connection:
 - Before installation and maintenance make sure that power supply to the electric lines has been turned off.
 - Use cables with minimum cross-sections, rated voltages and installation type that are suitable for the characteristics indicated in paragraph G ELECTRICAL SPECIFICATIONS.
 - Always close the cover of the terminal strip box before switching on the power supply, after having checked the integrity of the seal gaskets that ensure the IP55 protection grade.

- Cables with faston connector coupling for connection to the power supply line;
- RED cable: positive pole (+)
- BLACK cable: negative pole (-)
- Terminal strip box (protection class IP55 in conformance with the directive EN 60034-5-97) complete of:
 - ON/OFF switch;
 - Safety fuse against short circuits and overcurrent, featuring the following characteristics: 25A for 12V models 15A for 24V models
 - power cable complete of pinners for connection to the battery
 - RED cable: positive pole (+)
 - BLACK cable: negative pole (-)

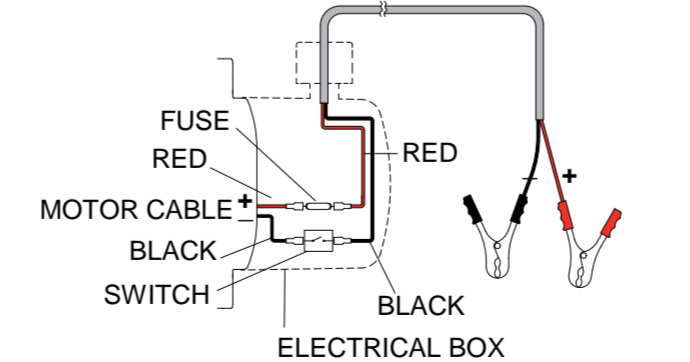

ATTENTION It is the installer's responsibility to perform the electrical connections with respect for the applicable regulations.

ENGLISH
(Translated from Italian)

L2 CONNECTING THE PIPING

- Before any connections, please refer to the indications (sticker on the pump) to detect suction and delivery univocally.
- Before connecting, make sure that the pipes and the suction tank are free of dirt and thread residue, which could damage the pump and accessories.
- Before connecting the delivery pipes, partially fill the pump body with the liquid that needs to be pumped (available only for versions with threaded inlet/outlet).
- Do not use conical threaded fittings, which could damage the threaded inlet or outlet openings of the pumps if excessively tightened.
- The MINIMUM recommended characteristics for hoses are as follows:

SUCTION PIPES: - recommended minimum nominal diameter: - nominal recommended pressure: 10 bar - use pipes that are suitable for operation with back pressure.

ATTENTION

The provided tubes have a resistivity of <1 MOhm, as specified by the EN 13617-1 standard. All the installed tubes that are different from those supplied, must have the above mentioned characteristics. When the connections are completed, the installer should check that the resistivity of the assembly complies with the EN 13617 and EN 13612 standards.

- The use of tubes that are not suitable could cause damage to the pump or to persons, as well as pollution. Loosening of the connections (threaded connections, flanges, gasket seals) could cause serious ecological and safety problems. Check all the connections after the first installation on a daily basis. If necessary, tighten all the connections.

M INITIAL START-UP

- Check that the quantity of diesel fuel in the suction tank is greater than the amount you wish to transfer.
- Make sure that the residual capacity of the delivery tank is greater than the quantity you wish to transfer.
- Do not run the pump dry. This can cause serious damage to its components.
- Make sure that the tubing and line accessories are in good condition. Diesel fuel leaks can damage objects and injure persons.
- Never start or stop the pump by connecting or cutting out the power supply.
- Do not operate switches with wet hands.
- Prolonged contact with diesel fuel can damage the skin. The use of glasses and gloves is recommended.

ATTENTION Extreme operating conditions with working cycles longer than 30 minutes can cause the motor temperature to rise, thus damaging the motor itself. Each 30-minute working cycle should always be followed by a 30-minute power-off cooling phase.

In the priming phase the pump must always be air initially present in the entire installation out of the delivery line. Therefore it is necessary to keep the outlet open to permit the evacuation of the air.

- That the pump is not running completely dry;
- That the suction tubing is not allowing air to seep in;
- That the suction filter is not clogged;
- That the suction height does not exceed 2 m. (if the height exceeds 2 m, fill the suction hose with fluid);
- That the delivery tube is allowing the evacuation of the air.

N DAILY USE

- a. If using flexible tubing, attach the ends of the tubing to the tanks. In the absence of an appropriate slot, solidly grasp the delivery tube before beginning dispensing.
- b. Before starting the pump make sure that the delivery valve is closed (dispensing nozzle at the line valve).
- c. Turn the ON/OFF switch on. The by-pass valve allows functioning with delivery closed only for brief periods.
- d. Open the delivery valve, solidly grasping the end of the tubing.
- e. While dispensing, do not inhale the pumped product.
- f. Should you spill any fluid while dispensing, bank it with earth or sand to absorb it and limit its spreading.
- g. Close the delivery valve to stop dispensing.
- h. When dispensing is finished, turn off the pump.

ATTENTION Functioning with the delivery closed is only allowed for brief periods (2 / 3 minutes maximum). After use, make sure the pump is turned off.

O MAINTENANCE

Thanks to the design, the pump requires simple maintenance. Before carrying out any maintenance work, disconnect the pump from any electrical and hydraulic power source. During maintenance, the use of personal protective equipment (PPE) is compulsory. In any case always bear in mind the following basic recommendations for a good functioning of the pump:

- ONCE A WEEK:
 - Check that the pipe connections are not loose to prevent any leaks;
 - Check and keep the filter installed on the suction line clean.

- ONCE A MONTH:
 - Check the pump body and keep it clean and free of any impurities;
 - Check that the electrical supply cables are in good condition.

ATTENTION Do not put your fingers into the pump openings while the pump is working.

P NOISE LEVEL

Under normal working conditions the noise emission from all models does not exceed the value of 70 db at a distance of 1 meter from the electric pump.

ENGLISH
(Translated from Italian)

Q PROBLEMS AND SOLUTIONS

For any problems contact the authorised dealer nearest to you.

PROBLEM	POSSIBLE CAUSE	CORRECTIVE ACTION
THE MOTOR IS NOT TURNING	Lack of electric power Rotor jammed	Check the electrical connections and the safety systems. Check for possible damage or obstruction of the rotating components.
THE MOTOR TURNS SLOWLY WHEN STARTING	Low voltage in the electric power line Foot valve blocked Filter clogged	Bring the voltage back within the anticipated limits Clean and/or replace the valve Clean the filter
LOW OR NO FLOW RATE	Excessive suction pressure	Lower the pump with respect to the level of the tank or increase the cross-section of the tubing
	By-pass valve blocked	Dismantle the valve, clean and/or replace it
	Air entering the pump or the suction tubing	Check the seals of the connections
	A narrowing in the suction tubing	Use tubing suitable for working under suction pressure
INCREASED PUMP NOISE	Low rotation speed	Check the voltage at the pump. Adjust the voltage and/or use cables of greater cross-section
	The suction tubing is resting on the bottom of the tank	Raise the tubing
LEAKAGE FROM THE PUMP BODY	Cavitation occurring	Reduce suction pressure
	Irregular functioning of the by-pass	Dispense fuel until the air is purged from the by-pass system
	Air present in the diesel fuel	Verify the suction connections
	Seal damaged	Check and replace the seal

**BY PASS 3000
CARRY 3000
BATTERY KIT 3000**

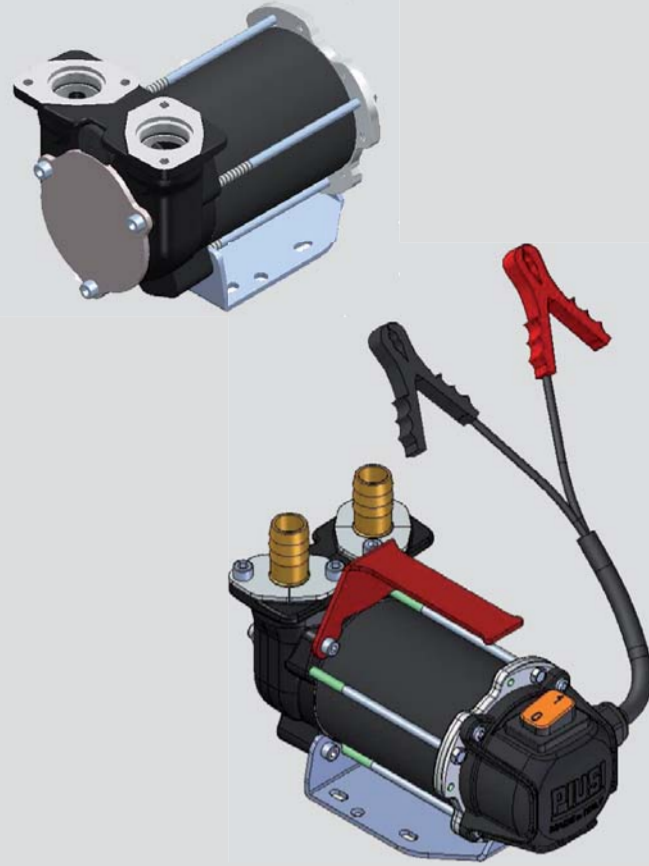

MANUALE D'USO E MANUTENZIONE Italiano

USE AND MAINTENANCE MANUAL English

Bulletin M01921TEN rev. 1

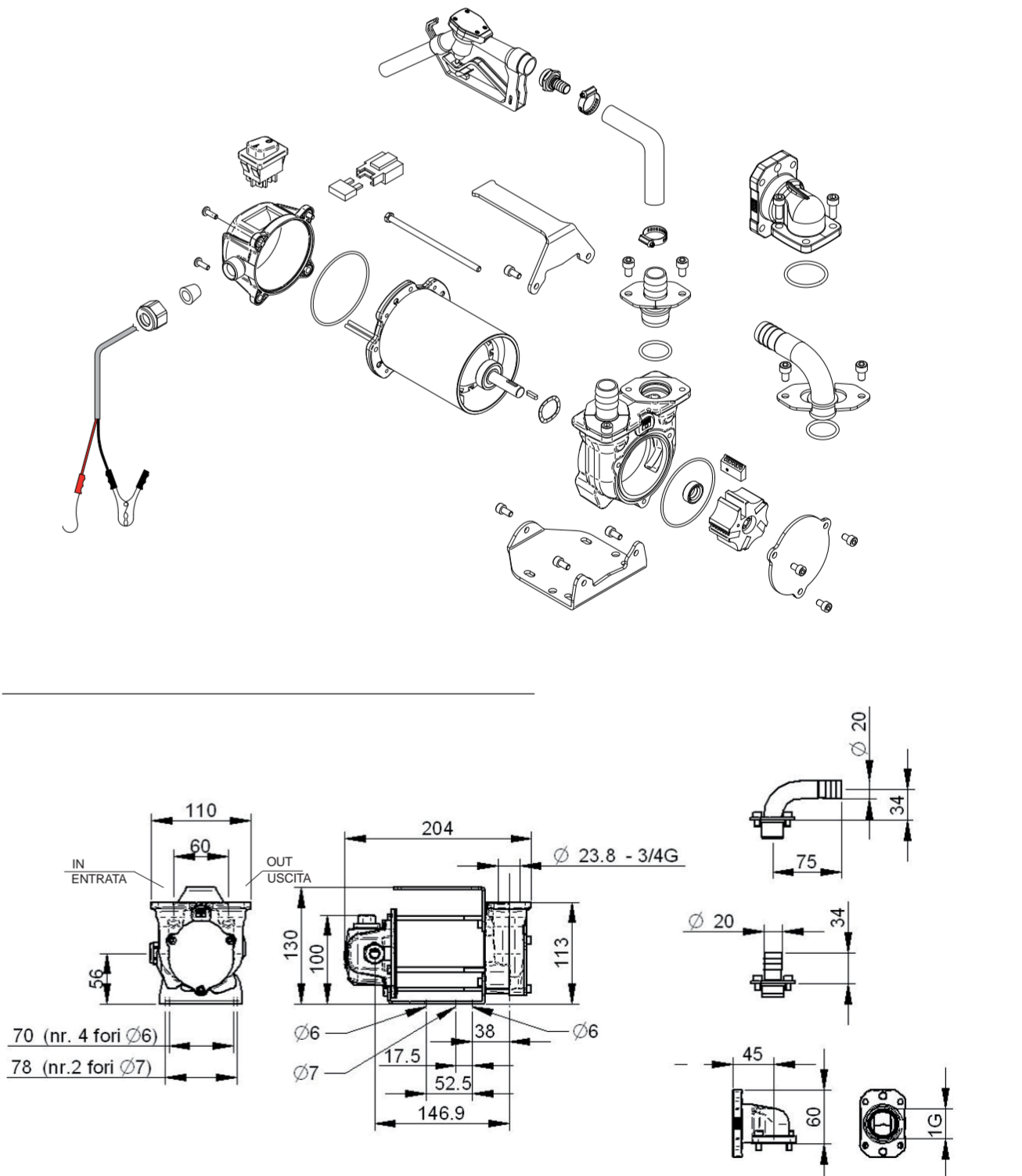

Bulletin M01921TEN rev 1