

HUSKY X

AUTOMATIC SHUT-OFF NOZZLE

Husky X Nozzle:

- Automatic shut-off nozzle.
- Husky X nozzle shuts off - when the gas tank is full.
- Nozzle is equipped with unique Flo-Stop device that shuts off nozzle if it falls from fill tank or raises above the horizontal.
- Nozzle comes with smooth Full Grip Guard. Waffle Splash Guard (as shown) is optional.
- Steel reinforced spout bushing keeps spout tip round, and acts as a captive fastener to prevent tip-end sensor damage.

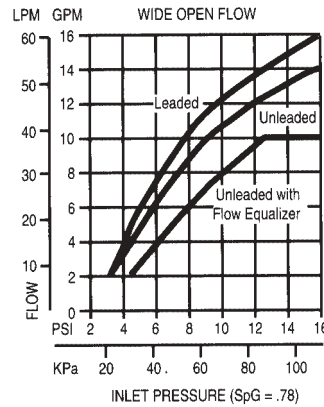

- Standard Flo-Equalizer regulates flow to 10 GPM max.



Shown with optional Waffle Splash Guard.

SPECIFYING INFORMATION

Model Number	Fuel	Hold-open Clip	Weight Lbs. (kg.)	Thread
159404	Unleaded	yes	2.5 (1.13)	NPT
159408	Unleaded	no	2.5 (1.13)	NPT
159403	Leaded	yes	2.6 (1.58)	NPT
159407	Leaded	no	2.6 (1.58)	NPT
159416	Unleaded	yes	2.5 (1.13)	BSP
159415	Leaded	yes	2.6 (1.58)	BSP

CONSTRUCTION

Body	One piece die cast aluminum
Disc	Viton® (Fluorocarbon)
Packing	Double O-Ring seal protected by Fiber Reinforced Teflon
Lever	One piece contoured steel with hard plastic cover
Inlet	3/4" NPT, BSP

PATENTS AND LISTINGS

Patent Nos.	4,825,916 D301366
Listings	U.L. U.L.C.

Viton® is a registered trademark of DuPont Dow Elastomers



HUSKY X

AUTOMATIC SHUT-OFF NOZZLE

- ACCESSORIES
- FEATURES
- DIMENSIONS

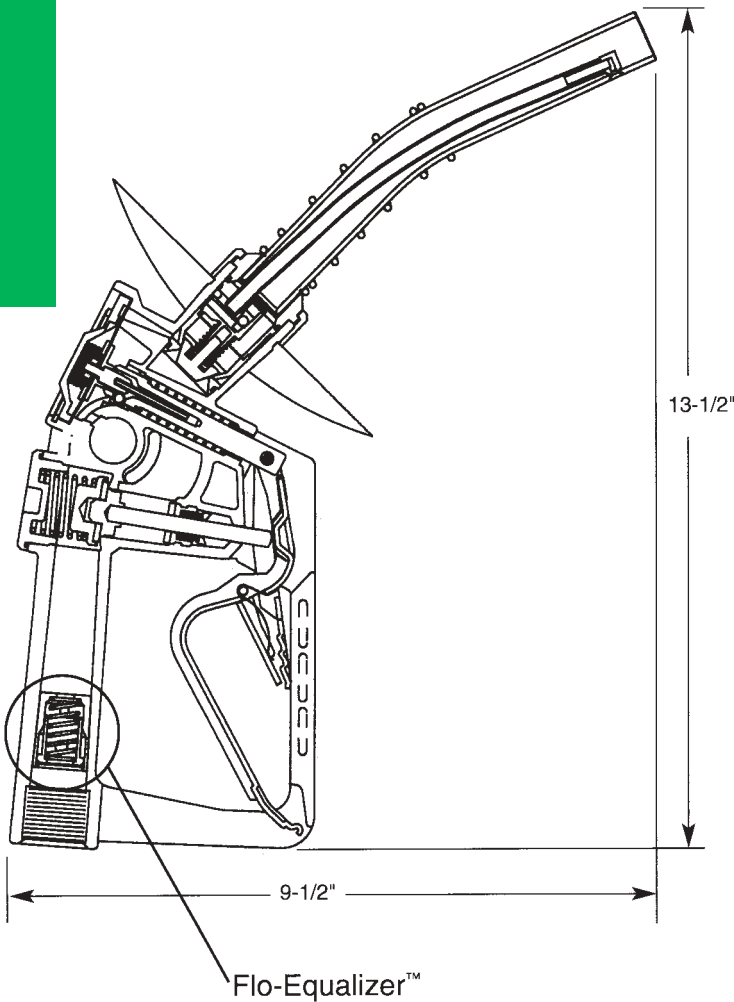

SAFE-T-BREAKS®	Model No.	Description
	2273	3/4"F x 3/4"F NPT
	3360	3/4"F x 3/4"F NPT (Reconnectable)

SWIVELS	Model No.	Description
	0350	3/4"M x 3/4"F Multi-plane
	0355	3/4"M x 3/4"F Multi-plane (black body)
	2272	3/4"M x 3/4"F 90° Pump Swivel

SPOUTS	Model No.	Description
	1473	Unleaded
	1471	Leaded

GUARDS	Model No.	Description
	4145	Full Grip Guard (smooth)
	1806	Full Grip ReGuard
	1808	Waffle Gas Guard
	2573	Clip-on Trigger Cover

GUARD PKGS.	Model No.	Description
	1809	ReGuard Package
	1506	Protection Package

