



Large capacity fuel tank with cabinet & roller shutter door

[Product Description]

8700 litre fully bunded fuel storage tank with a fuel dispensing cabinet, lockable anti-vandal door and strong steel base. The 8700 litre bulk fuel tank features a double cylinder construction using 4mm steel throughout. A removable manway provides access to the inner tank. The tank can be lifted using either the two lifting eyes or the forklift pockets.

[Specification includes]

- ▲ Double cylinder design with all-steel construction
- ▲ 2 point lifting eyes
- ▲ 110% bund capacity
- ▲ Suction line dip tube for fuel delivery - 1" with anti-siphon valve
- ▲ 1/2" BSP generator feed and return connections
- ▲ Large 3" breather and 2" BSP fill points, 3" sight glass
- ▲ 2" offset fill pipe with overflow prevention valve
- ▲ Removable manway for access into inner tank
- ▲ Cabinet with anodised aluminium roller shutter door or heavy hinging steel doors
- ▲ Sturdy base with forklift pockets
- ▲ Cube 70 fuel dispensing system

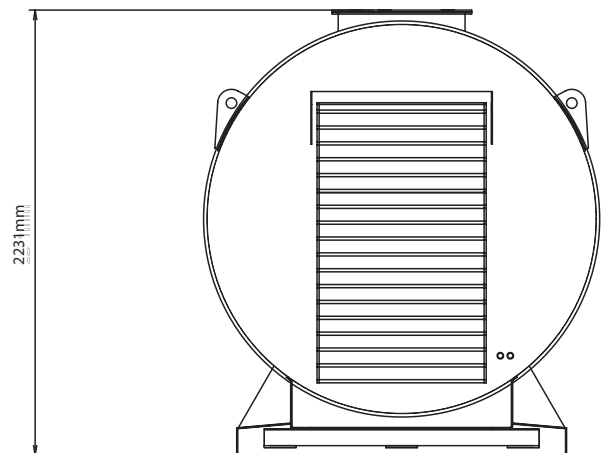

[Optional extras]

- ▲ Ultrasonic remote oil level monitor
- ▲ Combined overflow, low-level and bund alarm (240V or battery powered)
- ▲ 35 litre spill kit
- ▲ Fuel Management System

[Technical Information]

Length:	4028mm
Width:	1980mm
Height:	2231mm
Capacity:	8700 litres (1910 gallons)
Weight (empty):	2150kg
Weight (full):	9720kg
Filler neck:	2" & 3" BSP
Fuel delivery:	70 litre/min PIUSI Cube

