

Harlequin TransFuel



The Harlequin TransFuel is the UK's first bunded ADR approved mobile refuelling tank made from lightweight MDPE

By combining a fully bunded fuel tank with an 12v transfer pump set, Harlequin have managed to provide an environmentally compliant system at a market leading price.

Featuring a PIUSI brand 12v dispensing system, the equipment comprises of a self priming transfer pump with 4m delivery hose and automatic trigger nozzle.

Installation is quick and simple, the tank is ready to use as soon as it is offloaded and features both lifting eyes and convenient forklift pockets.

Specification

Manufacturer	Harlequin Plastics Ltd
Type	Fully Bunded MDPE Tank with Integral Dispensing System
Model	430TFD
Volume	414 litre (nominal capacity)
Colour	Grey with Orange Lid
ADR CERT No	31HH1/Z/** **/GB/CH/-6003/0/453

Equipment

Pump	12v AC 56 litre/min Piusi BP3000 as standard, other options below.
Delivery Hose	4m x 25mm Fuel Delivery Hose
Nozzle	Automatic Nozzle (3-speed)
Gauging	Optional K24 Electronic Flow Meter
Security	Locking Hinged Door

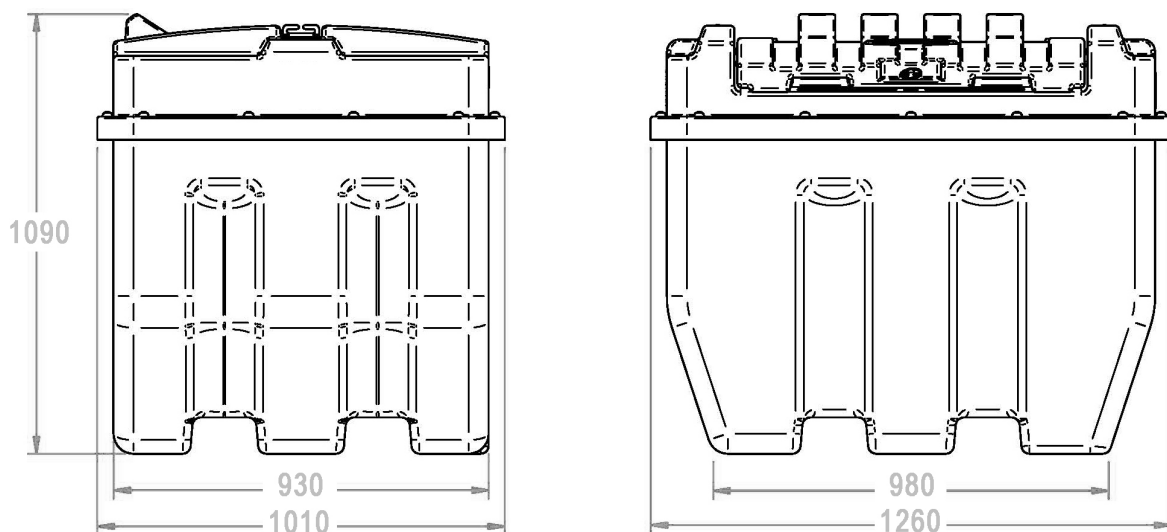

The Harlequin Transfuel is supplied with 12v pump as standard (24v DC & 230v AC on request)