

BY-PASS 3000 The Original



DC fuel transfer pump

Displacement, self-priming, rotary electric vane pumps for the transfer of diesel fuel equipped with by-pass valve.

Powerful, dependable and economical, they are available with 12 and 24-volt direct current motors.

Thanks to their compact size, ease of installation, dependability and safety, these pumps are used as the primary system on earth-moving machinery and on mobile fuel pumps on vehicles or in construction yards.

Technical Specifications

- Cast iron pump body finished with anti-corrosion paint.
- Vane pump with sintered steel rotor and acetal resin vanes.
- By-pass valve incorporated in the pump body.
- Direct current brush motor with permanent magnet stator.
- Motor protection grade IP55.
- Used in intermittent service with 30-minute work cycles.
- Pump attachment support bracket.

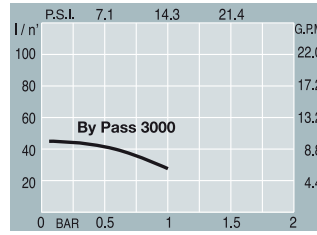

On request



• KIT terminal box + 2mt cable + fuse 25A with clamp BP3000 12V Code F16293000

• KIT terminal box + 4mt cable + fuse 25A with clamp BP3000 12V Code F16295000

• KIT terminal box + 2mt cable + fuse 15A with clamp BP3000 24V Code F16294000

• KIT terminal box + 4mt cable + fuse 15A with clamp BP3000 24V Code F16296000

Terminal box Code F1601100A



Available:

CARRY3000



With cable length 2 m



REGISTERED DESIGN

Flow rate up to 50 l/min

12 Volt working

24/12 Volt working

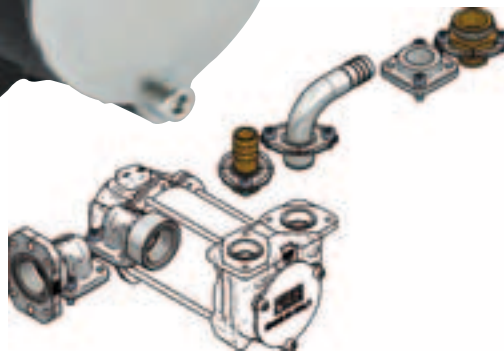

Choose your best connections

Kit straight hose tail 3/4" Code F16172000 (No.02 pcs)



90° hose tail 3/4" Code F16173000 (No.01 pcs)





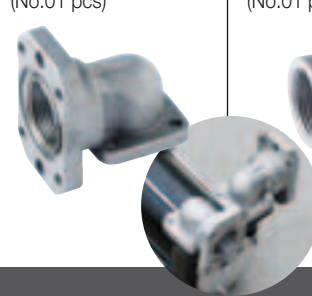

Flanged elbow 1" BSP Code F16178000 (No.01 pcs)

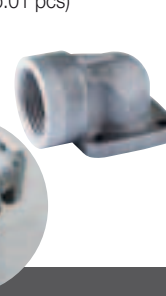

Flanged elbow 1" BSP Code F16770000 (No.01 pcs)



Code	Description		Flow rate		DC				Max working pressure bar	Fuse Amp	Weight Kg	Packaging mm
			l/min	gal/min	Volt	rpm	Amp	Duty cycle min				
F00342000	BP3000 12V		50	13	12	2900	22	30	1,5	-	3,5	200x350x270
F00347000	BP3000 24V / 12V		50/30	13/6	24/12	2900/1500	11/6	30	1,5	-	3,5	200x350x270
F0022300C	Carry 3000 12V		50	13	12	2900	22	30	1,5	25	4,2	215x120x160
F0022400C	Carry 3000 24V / 12V		50/30	13/6	24/12	2900/1500	11/6	30	1,5	15	4,2	215x120x160